

Mounting to round bar or ATV/UTV with optional tube clamps available from 3/4" to 4" dia.

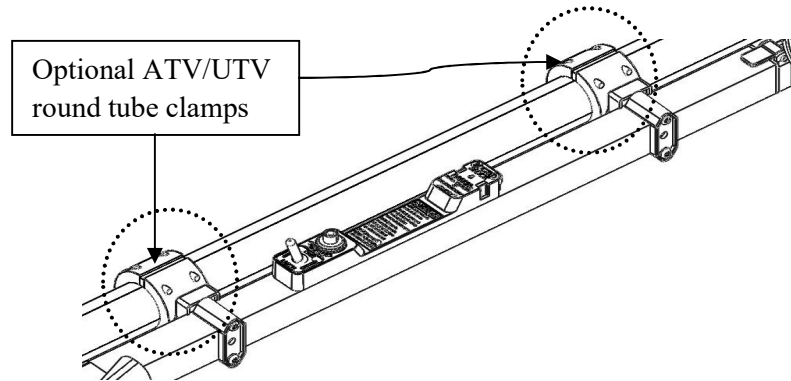

Measure the dia. of the tube and use the proper optional round tube clamps.

Identify the location for mounting the Locked Stock & Barrel by holding the unassembled tube body against the desired tube. Then install the muzzle cup and buttstock holder (see basic assembly doc) in the proper orientation to fit the selected location.

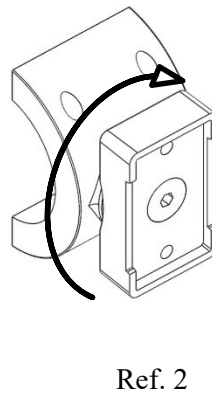
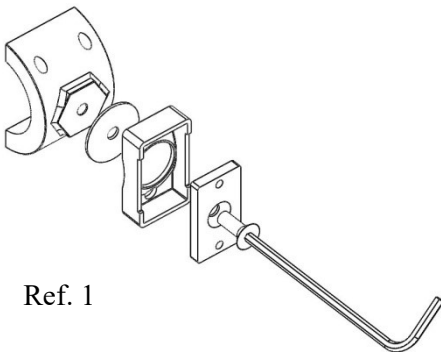

As shownt in Ref. 1 above, loosely assemble the components shown for both clamps. When assembled, the lower clamp body should be able to rotate lightly (Ref. 2). **DO NOT** tighten firmly.

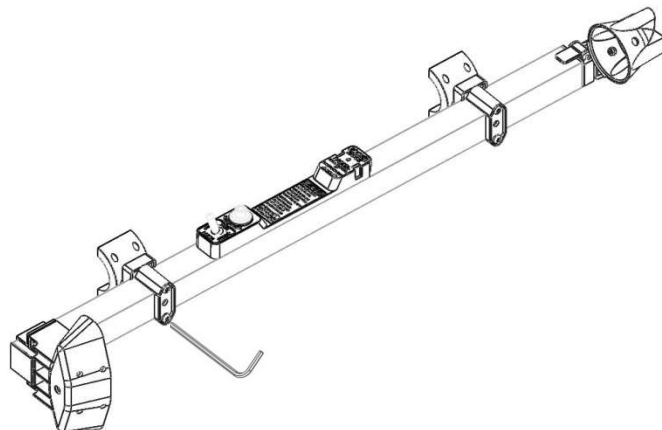

Place the U shaped upper clamp over the Locked Stock & Barrel and loosely attach to the lower clamp using the four longer screws. Do Not firmly tighten until installation is complete.

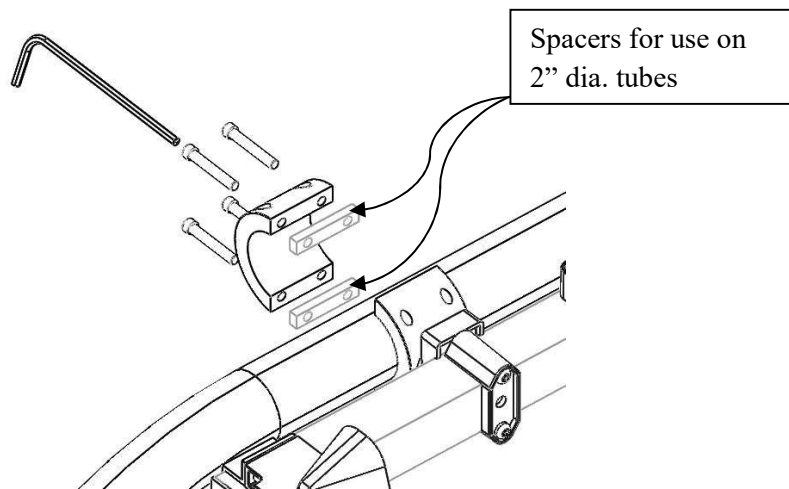

Place the LS&B with partial clamps against the tube and loosely install clamp back and spacers, if required for your tube diameter.

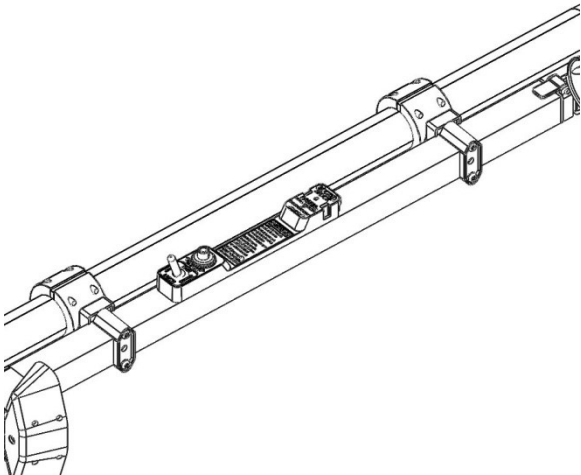

Slide and rotate the LS&B into its desired location and tighten the eight back clamp screws and the four upper clamp screws.